

# SPR-CX SERIES

## COAX SERIES SIGNAL / DATA LINE SURGE SUPPRESSOR



---

### FEATURES:

- ▶ Designed for low insertion loss protection of equipment utilizing coaxial line interconnects.
- ▶ Aluminum shielded enclosure with greater than 70 dB of RFI noise rejection.
- ▶ Attractive, low profile, wall mounted suppressor.
- ▶ Standard BNC, BNC Twin-Ax, F, or N connectors with various male/female input/output options readily available.
- ▶ Suppressor automatically resets and requires no maintenance.
- ▶ Hermetically sealed and suitable for the most harsh environments.
- ▶ Exceeds severity level of 4 IEC/EN 61000-4-5
- ▶ Sub nanosecond response time stops failures due to lightning, spikes and over-voltage surges on incoming signal/data lines.
- ▶ Maximum insertion loss less than 0.5 dB for high speed data transmission.

---

### Applications:

The SPR-CX Series is designed to protect radio equipment using standard coaxial interface: Network equipment, video equipment, transmission/data processing equipment, and communication networks such as DH+, Control-Net, etc.

This series may be used on high speed data lines, video surveillance lines and antenna lead wire.

Select the model according to the operating voltage and connector type from the table found on the reverse side of this data sheet.

---

### Typical Installation:

Screw mount the SPR-CX Series suppressor to any convenient surface. Connect the field and equipment lines to the suppressor as indicated. The suppressor base plate must be connected to a good earth ground. Keep the ground wire (#12 AWG or larger) short and place the suppressor as near the equipment it is to protect as possible. A suppressor should be placed at both ends of a coaxial line if both ends connect to electronic equipment.

# SPR-CX SERIES OPERATING SPECIFICATIONS:

| Specifications                        | SPR-CX12                                   | SPR-CX12A  | SPR-CX12F  | SPR-CXN    | SPR-CXNA   | SPR-CXT                 |
|---------------------------------------|--|------------|------------|------------|------------|-------------------------|
| Maximum Operating Line Voltage        | ± 12 Volts                                 | ± 12 Volts | ± 12 Volts | ± 24 Volts | ± 24 Volts | ± 12 Volts              |
| Minimum Breakdown Voltage             | 13 Volts                                   | 13 Volts   | 13 Volts   | 60 Volts   | 60 Volts   | 13 Volts                |
| Maximum Operating Current             | 200 mA                                     | 200 mA     | 200 mA     | 200 mA     | 200 mA     | 200 mA                  |
| Maximum Surge Voltage (1.2 x 50 µSec) | 20 kV                                      | 20 kV      | 20 kV      | 20 kV      | 20 kV      | 20 kV                   |
| Maximum Surge Current (8 x 20 µSec)   | 10.0 kA                                    | 10.0 kA    | 10.0 kA    | 40 kA      | 40 kA      | 10 kA                   |
| Maximum Capacitance                   | 200 pF                                     | 200 pF     | 200 pF     | 1 pF       | 1 pF       | 200 pf                  |
| Maximum Insertion Loss                | 0.5 dB                                     | 0.5 dB     | 0.5 dB     | 0.1 dB     | 0.1 dB     | 0.5 dB                  |
| Maximum Throughput Resistance         | 3 Ohms                                     | 3 Ohms     | 3 Ohms     | 3 Ohms     | 3 Ohms     | 3 Ohms                  |
| End Connector Type*                   | BNC (F-F)                                  | BNC (F-M)  | F (F-F)    | N (F-M)    | N (F-F)    | BNC Twin-Ax (Jack-Jack) |
| Response Time                         | Less than 1 nanosecond                     |            |            |            |            |                         |
| Operating & Storage Temperature       | -40 Degrees Celsius to +85 Degrees Celsius |            |            |            |            |                         |

All components meet flammability ratings of UL's 49V-0, 94V-2 and CSA standards. Design is compliant with UL-497 and FCC Parts 68 and 15. All specifications at 25 degrees Celsius. \*Alpha characters in ( ) represent gender.

## Typical Installation:

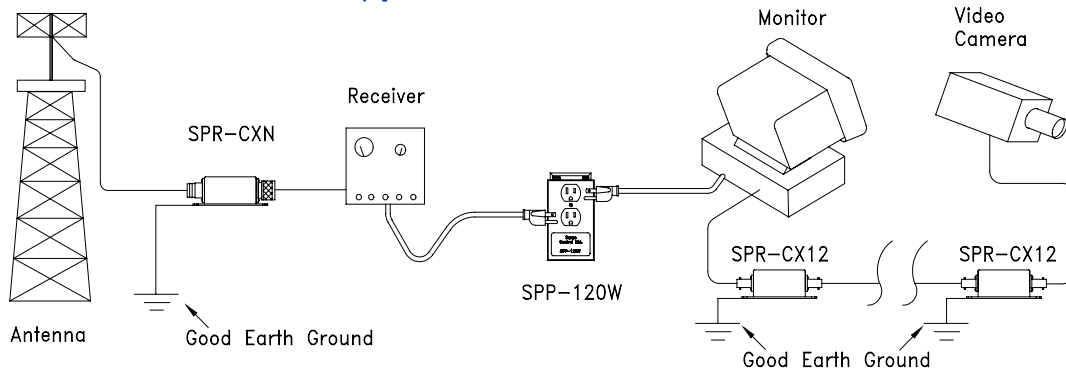

## Outline Dimensions:

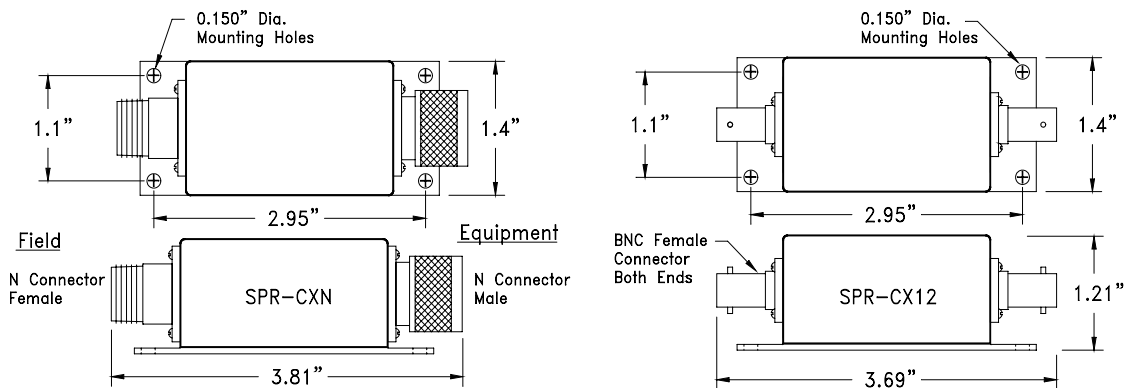

**Circuit Components, Inc.**  
 2400 S. Roosevelt Street Tempe, AZ • 85282  
 Tel: 480-967-0624 • Fax: 480-967-9385  
 Email: [info@surgecontrol.com](mailto:info@surgecontrol.com) • Website: [www.surgecontrol.com](http://www.surgecontrol.com)

**SURGE CONTROL**®  
 A PRODUCT OF CCI

This information is not intended to and does not create any warranties, expressed or implied, including any warranty of merchantability or fitness for a particular purpose. Circuit Components Inc. reserves the right to change specifications at any time without notice.